

**Condensate Pump, type *Guardian Plus* Unit  
Installation and Maintenance Instructions**

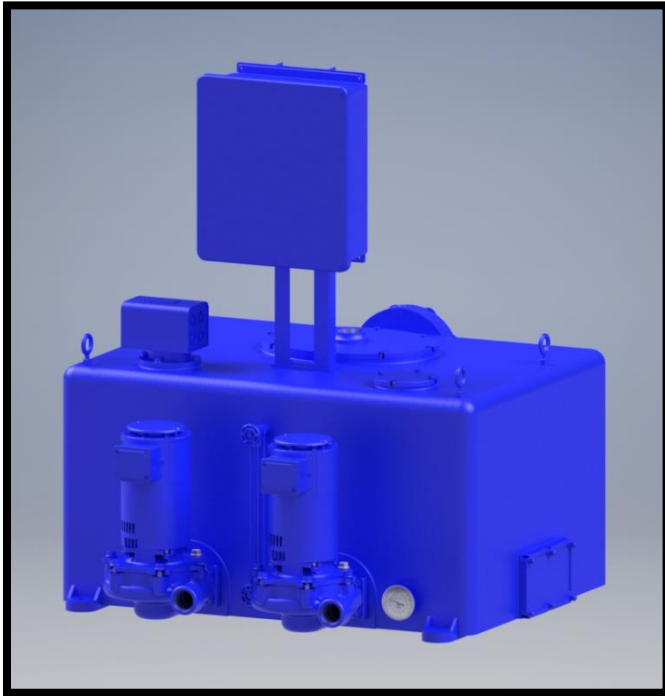

*Guardian Plus* Condensate Return

*Guardian Plus* Boiler Feed

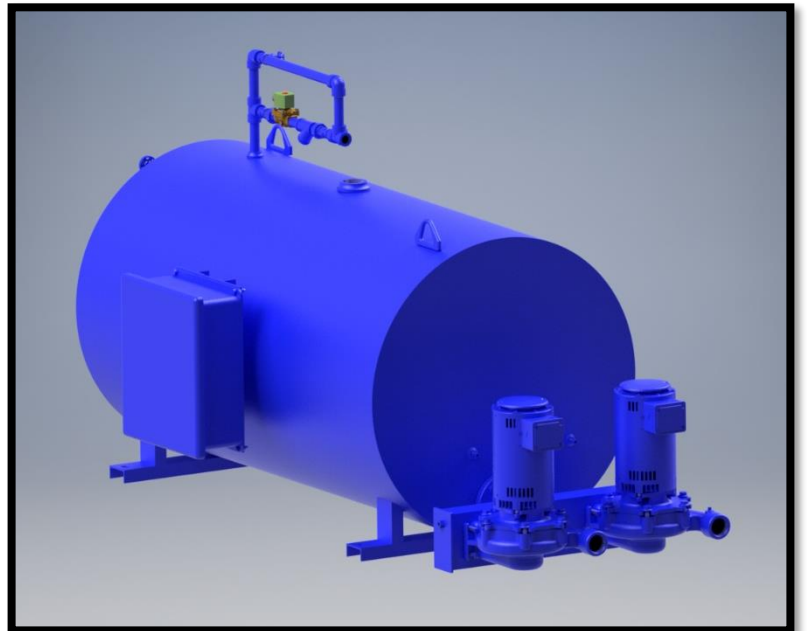

---

## INTRODUCTION

This form contains information necessary to install, operate and maintain *Guardian Plus* Condensate Units manufactured by Vent-Rite. The information is assembled in order, from receiving the product to its proper maintenance, to enable you to follow the product through the various steps necessary to implement.

---

## INSTALLATION

**A. Receiving Inspection.** When the unit is delivered, an immediate visual inspection of the unit and its accessories should be made in the presence of the carrier's representative. If there is any evidence of rough handling or damage, a notation should be made on the delivery receipt. Shipping damages are the responsibility of the carrier, and it is the customer's responsibility to file the claim.

**B. Uncrating.** When uncrating the unit be sure that all temporary plugs remain in their tapping until you are ready to connect the pump to the system, and all instructional tags are attached. Locate the unit in a clean, dry, well ventilated and drained location. The top of the pump receiver should be below the lowest return to maintain dry return lines. If receiver is above the lowest return, the returns will be wet, and the system will not free itself of air.

**C. Rigging.** Each unit has been carefully tested and inspected at the factory where every precaution was taken to ensure that it reaches its destination in perfect condition. It is very important that the installers, movers, and riggers use the same care in handling of the unit. Chains, cables, or other moving equipment should be placed to avoid damage to any part of the unit.

**D. Piping Connections.** All piping should be tight and properly supported by hangers, not by connections. Connect returns to inlet of receiver with a Vent-Rite gate valve in each return and a union or flange joint next to the receiver. Connect discharge of pump to boiler using a union, swing check valve and gate valve, with the swing

The *Guardian Plus* Condensate Units are complete assemblies for returning condensate to low pressure boilers from gravity heating systems, low pressure steam process equipment, or from combinations of both. They are used where low return mains are located at elevations which do not permit gravity flow of condensate to the boiler.

check valve as close to pump as possible. Piping must be of proper length and size to prevent any strain upon the unit. **WARNING:** Venting to same room may cause humidity which can lead to damaged equipment (pumps, control panels, etc.). Vent to exterior of building when possible.

**E. Wiring.** The electrical connections between the motor, float switch and automatic starter (if furnished) are made at the factory. Connect the electric service to the float switch or automatic starter using conduit and wire sizes as required by state/local codes. Provide a fused main line switch in motor circuit. **CAUTION:** The motor is wired at the factory to operate at the voltage specified. If voltage is other than originally specified, consult motor manufacturer's instructions accompanying unit for proper wiring. Where a polyphase motor is furnished with only a float switch, IT WILL BE NECESSARY TO INSTALL A SUITABLE PHASE PROTECTOR SWITCH IN THE MOTOR CIRCUIT TO PREVENT MOTOR BURNOUTS SHOULD A SINGLE-PHASE CONDITION OCCUR.

**F. Fuses.** Be sure fuses are installed which comply in size with NEC (National Electrical Code) recommendations. When a fuse blows out, it indicates that something is wrong either in the motor, pump, switch, fuse rating or electric service. Do not replace fuse until the cause has been determined. If a thermal cut-out is used, an element with a maximum tripping current rating 50% greater than motor nameplate Amperes may be selected. Condensate boiler feed pumps operate intermittently and are therefore permissible.

---

## OPERATION

Before placing the unit in service, operate the system for at least several days, wasting the condensate to the sewer through draw-off to remove dirt, grease, scale and other foreign matter. When discharging condensate to sewer, supply make-up water to boiler to maintain proper water line.

On installations equipped with manually operated coal, oil or gas-fired boilers an automatic water feeder is recommended. A low water cut-out of fuel supply should be installed on all installations equipped with automatically operated stoker, oil or gas-fired boilers.

### For Trial Operation of Unit, Proceed as Follows:

1. Shut power off to unit.
2. Remove plug on rear of motor and with large-bladed screwdriver, rotate shaft to be sure pump is free.
3. Jog pump to ensure correct pump rotation (Clockwise when viewed from the top). **Do not continuously operate pump without water in the receiving tank** as the pump is equipped with a mechanical shaft seal. Continuously operating the pump dry may ruin seal.
4. Fill the receiver tank with enough water to close the float switch.

- 
5. Open gate valve.
  6. The pump will discharge water from the receiving tank into the boiler, stopping automatically when water in receiving tank reaches a low level.

#### **OPERATING POINTS**

1. Check motor speed. If motor speed is low check wiring connections to motor. If wired for higher volt current than actual volt current, the motor will never come up to proper speed, and motor may burn out.
2. Lack of capacity may indicate that passageways of pump impeller have become clogged with foreign matter.
3. If the pump fails to start, it may be due to the float ball having lost its buoyancy. This can be checked

by operating the float head lever manually. If the float ball is not buoyant, replace with new float ball.

4. If after long service, water flows from around the motor shaft out through the space between the pump head motor flange and the pump head case flange, it is an indication of a mechanical seal failure, and the complete mechanical shaft seal should be replaced. Motor(s) not provided with grease fittings have bearings greased for life by motor manufacturer.

**PARTS** - When ordering parts, **give type, size and serial number shown on the pump nameplate.**

---

## **MAINTENANCE**

**INSPECTION.** To ensure best operation of unit, make a systematic inspection at least once a week.

**CLEANLINESS.** Keep the interior and exterior of motor and automatic switches free from moisture, oil and dirt. If necessary, use compressed air for blowing out dirt.

**FLOAT SWITCH** (Simplex) or **MECHANICAL ALTERNATOR** (Duplex) Occasionally examine contacts of automatic switches and see that they make a full firm contact and break the circuit quickly. Be sure all terminal connections are tight and not corroded.

**MECHANICAL SHAFT SEAL.** Occasionally examine water slinger on motor shaft and look for water leakage.

Any leakage will also be visible on seal plate. Leakage indicates that the seal surfaces are worn and will need replacing. **CAUTION:** Never operate pump when receiver is empty, because the seal will be damaged if run dry.

**SHUT DOWN.** At the end of the heating season, open main line switch, close valves in return line and discharge piping, - and drain receiver and pump. If necessary, cover electric motor and automatic switches to protect them against dirt, oil and moisture. **CAUTION:** Never operate pump when receiver is empty or expose it to freezing temperature when filled with water.

---

## TYPICAL SYSTEM CONNECTIONS

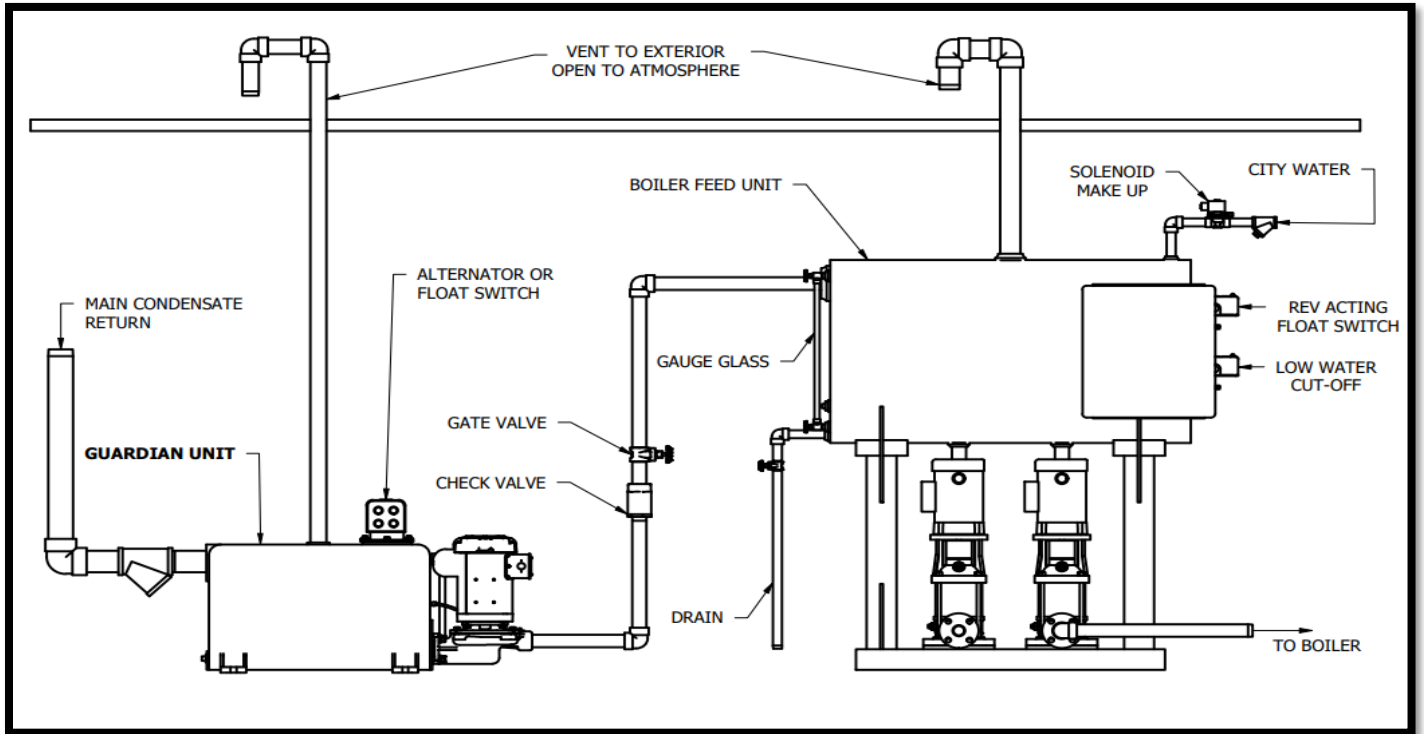

Figure 1

## TROUBLESHOOTING

A troubleshooting chart is shown below to enable you to isolate any problems you may encounter when operating the *Guardian Plus* Condensate Unit.

SYMPTOM	POSSIBLE CAUSE	REMEDY
1. No condensate discharge	1a. Not enough condensate in tank to prime pump. 1b. Speed too low. 1c. Discharge head too high. 1d. Impeller loose on shaft, plugged or worn.	1a. Check return lines from boiler. 1b. Check wiring connections to motor. 1c. Open discharge valve. 1d. Inspect pump end and motor. Repair and/or replace.
2. Insufficient condensate discharge	2a. Air or water leak. 2b. Plugged pump vent line. 2c. Speed too low. 2d. Impeller loose on shaft, plugged or worn.	2a. Check bleeder line. 2b. Disconnect vent line from Guardian Pump – Reconnect. 2c. Check motor wiring. 2d. Replace impeller. Check with manufacturer.
3. Pump does not start	3a. Motor lead connections may be wired wrong. 3b. Blown fuses in disconnect switch. 3c. Loose connection. 3d. Rotating assembly is bound.	3a. Check wiring diagram, page 2. 3b. Check fuses. 3c. Check wiring. 3d. Try turning motor shaft from top side of motor with screwdriver or open wrench.
4. Excessive power consumption	4a. Speed too high. 4b. Loose wiring connection. 4c. Mechanical defects: (1) Motor shaft bent (2) Rotating element binds (3) Foreign elements between impeller and wearing ring.	4a. Check voltage 4b. Check wiring connections. 4c. (1) Replace motor. (2) Reassemble & tighten parts. (3) Disassemble & check condition.
5. Pump is noisy	5a. Bearings bad (sealed bearings in motor) 5b. Pump may be operating at a low enough head to be in cavitation range. Cavitation sounds like pebbles rattling in a pail. 5c. Pump is operating too near shut-off head. 5d. Internal parts rubbing. 5e. Motor has magnetic hum or high windage noises.	5a. Check with motor manufacturer. 5b. Throttle discharge valve to correct pressure and lock. (If cavitation noise disappears it may be wise to install a smaller diameter impeller, reduce speed, or install an orifice on discharge). 5c. Check discharge piping to lower the head. 5d. Disassemble and check internal parts. 5e. check with motor manufacturer.
6. Loss of Suction following period of satisfactory operation	6a. Air leak at mechanical shaft seal or pump gasket. 6b. Pump vent line plugged. 6c. Air gasses in condensate or condensate too hot.	6a. Disassemble pump and motor unit. Replace mech. Shaft seal or gasket. Be sure all parts are clean. <b>Do not</b> scratch or mar seal component rings. Reassemble. <b>Never run pump with receiver empty. Damage to seal may result.</b> 6b. Flush. 6c. Check mechanical shaft seal and gasket.

Table 1

## Guardian® Boiler Feed Pumps (WITH MAKE-UP WATER VALVE)

The **Model GSB** (simplex unit) or **GSBD** (duplex unit) **Guardian Boiler Feed Pump** is designed for those installations where it is important to maintain the boiler water line within narrow limits, and to automatically supply “make-up” water from an outside source. Precise boiler line control is accomplished by governing the pump operation with a *Boiler Water Line Controller* installed at the boiler water line.

When the boiler requires water, the float operated switch in the *Controller* starts the pump motor(s) through magnetic starters that can be furnished as an optional extra. Water level is maintained in the pump receiver by an electric solenoid make-up valve activated by a reverse acting float switch. The construction of these pumps is similar to the **GS model** except that a water make-up circuit (solenoid valve and reverse acting float switch) is furnished.

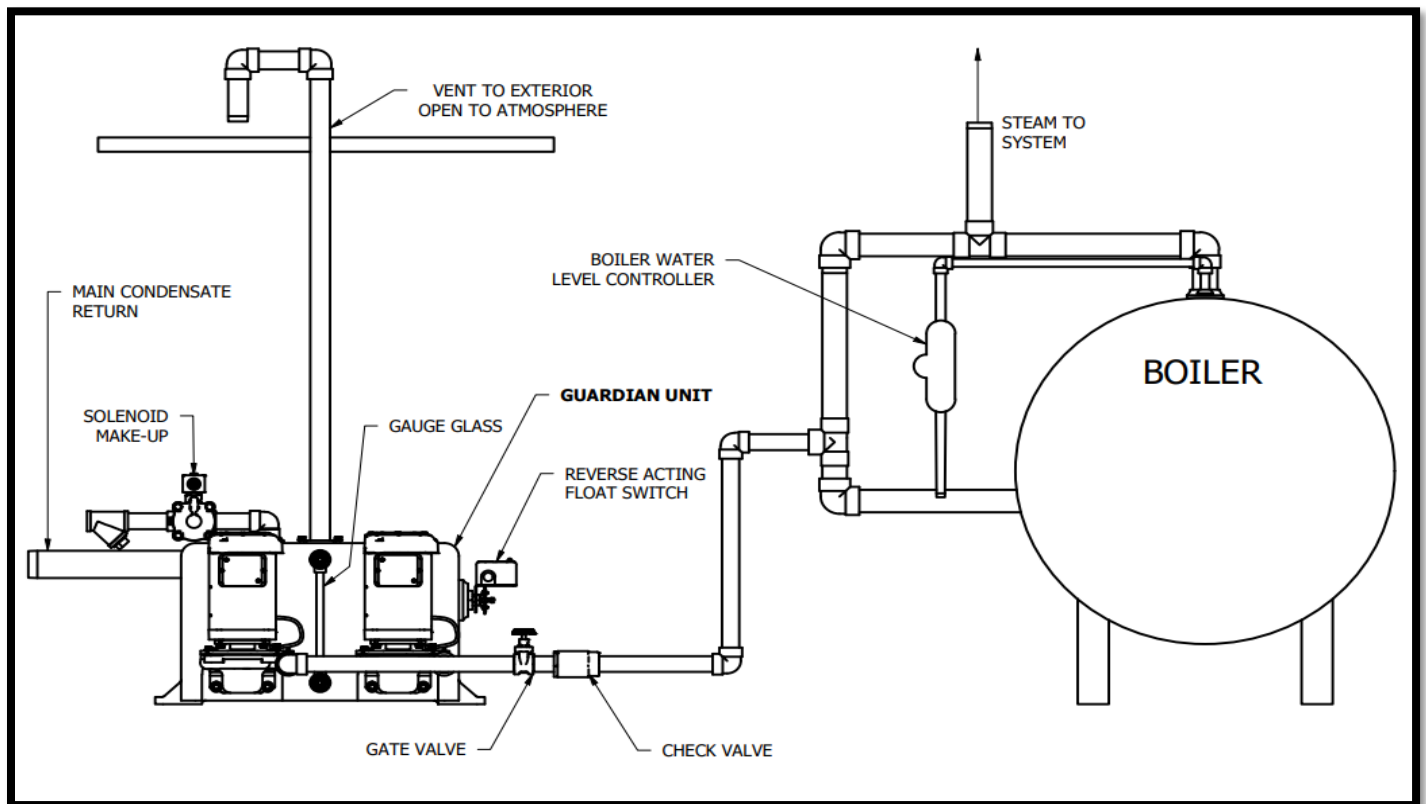
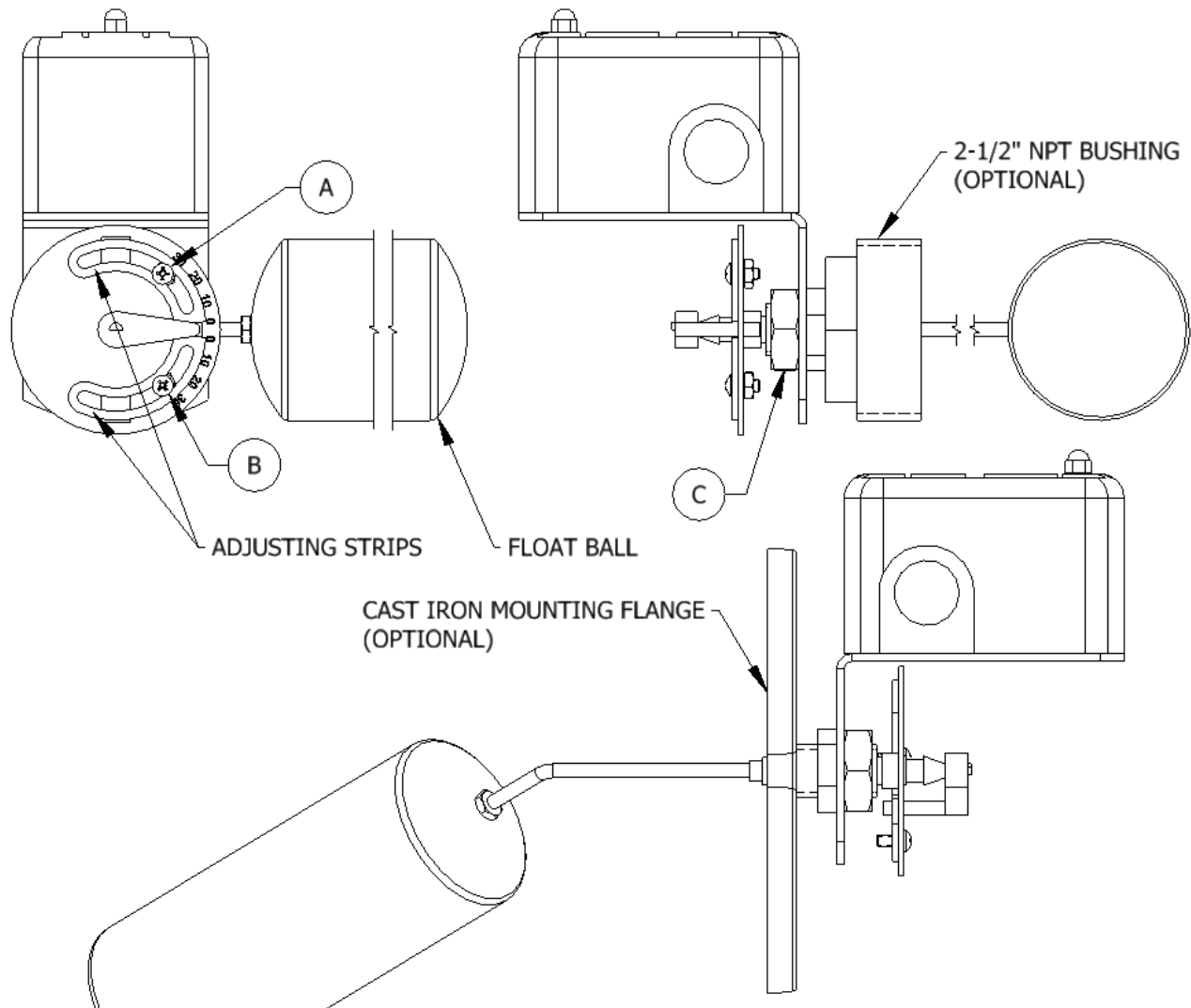

Figure 2

## SIDE MOUNT FLOAT SWITCH - MAINTENANCE INSTRUCTIONS



**⚠ WARNING**

**TO AVOID SHOCK HAZARD, DISCONNECT ALL POWER BEFORE INSTALLING OR SERVICING DEVICE.**

**Float Adjustment:** Floats that are shipped with a Vent-Rite unit will be pre-set to the proper float travel; however, if a replacement float switch is to be installed on an existing unit or if adjustment is required, travel may be adjusted via the adjusting strips, held in place by bolts "A" and "B". Track secured by bolt "A" determines upward limit of travel, with "B" determining the lower. Either may be adjusted by loosening their respective bolts and sliding the adjustment track to the desired angle.

Note: If possible, filling the tank to desired high or low point will allow adjusting strip to be fastened in exact location, with no guesswork or calculation required.

**Removing the Float Switch:** The side mount float switch can be mounted either with a 2-1/2" NPT bushing or a cast iron mounting flange. If a flange-mounted float must be removed from the tank, the nuts may be loosened on the flange and the float removed. Gaskets should be replaced if damaged. For the bushing mounted float switch, loosen the locking nut "C". This will allow the bushing to be rotated out of the tank and the float removed.

**Replacement Parts:** For replacement parts, contact your local Vent-Rite representative. Float switch arm and tank mounting configuration can differ from tank to tank, so be sure to provide the tank dimensions and mounting configuration in the request. Vent-Rite will not replace sub-components on the float switch, such as the float arm or switching mechanism.

**Wiring Diagrams:**

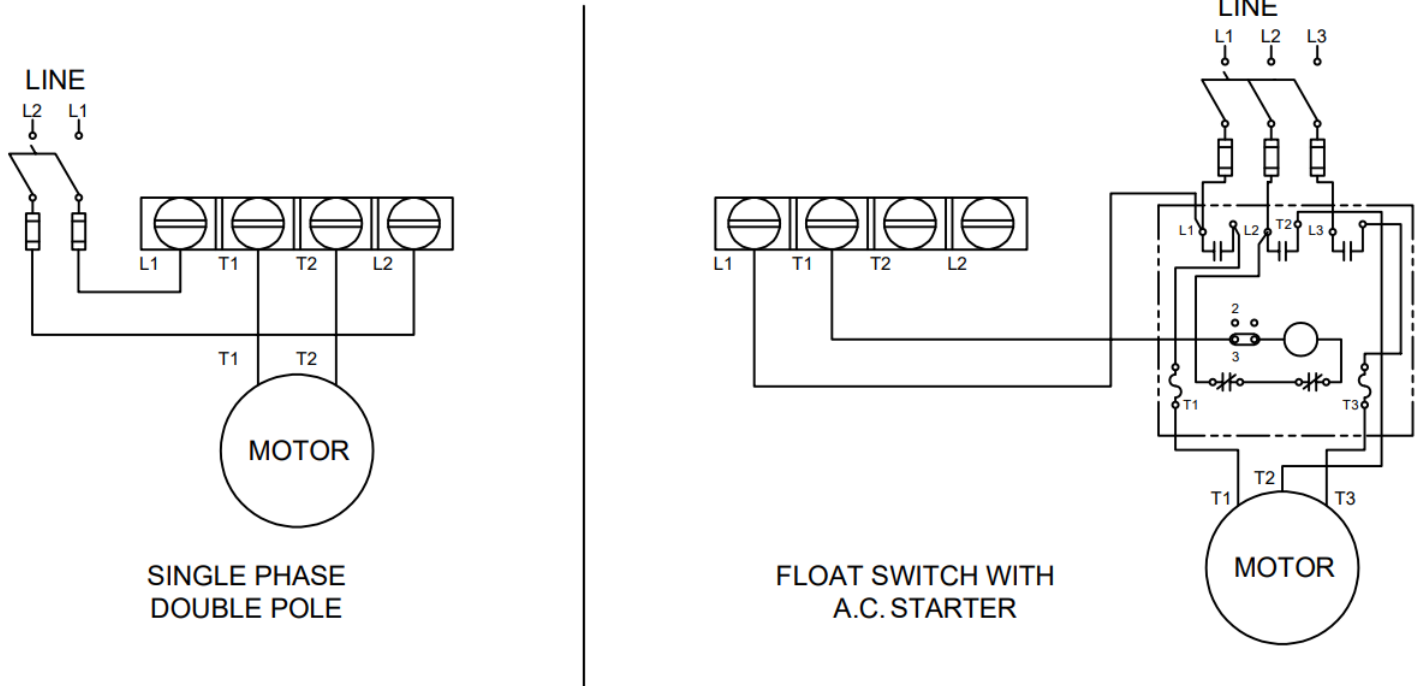

**Electrical Ratings:**

Voltage (V)	Single Phase AC	Three Phase AC	DC
<b>115</b>	2 HP	3 HP	1/2 HP
<b>208/230</b>	3 HP	5 HP	1/2 HP
<b>460/575</b>	-	1 HP	-
<b>32</b>	-	-	1/4 HP

Control Circuit Rating: A600

## SIDE MOUNT MECHANICAL ALTERNATOR - MAINTENANCE INSTRUCTIONS

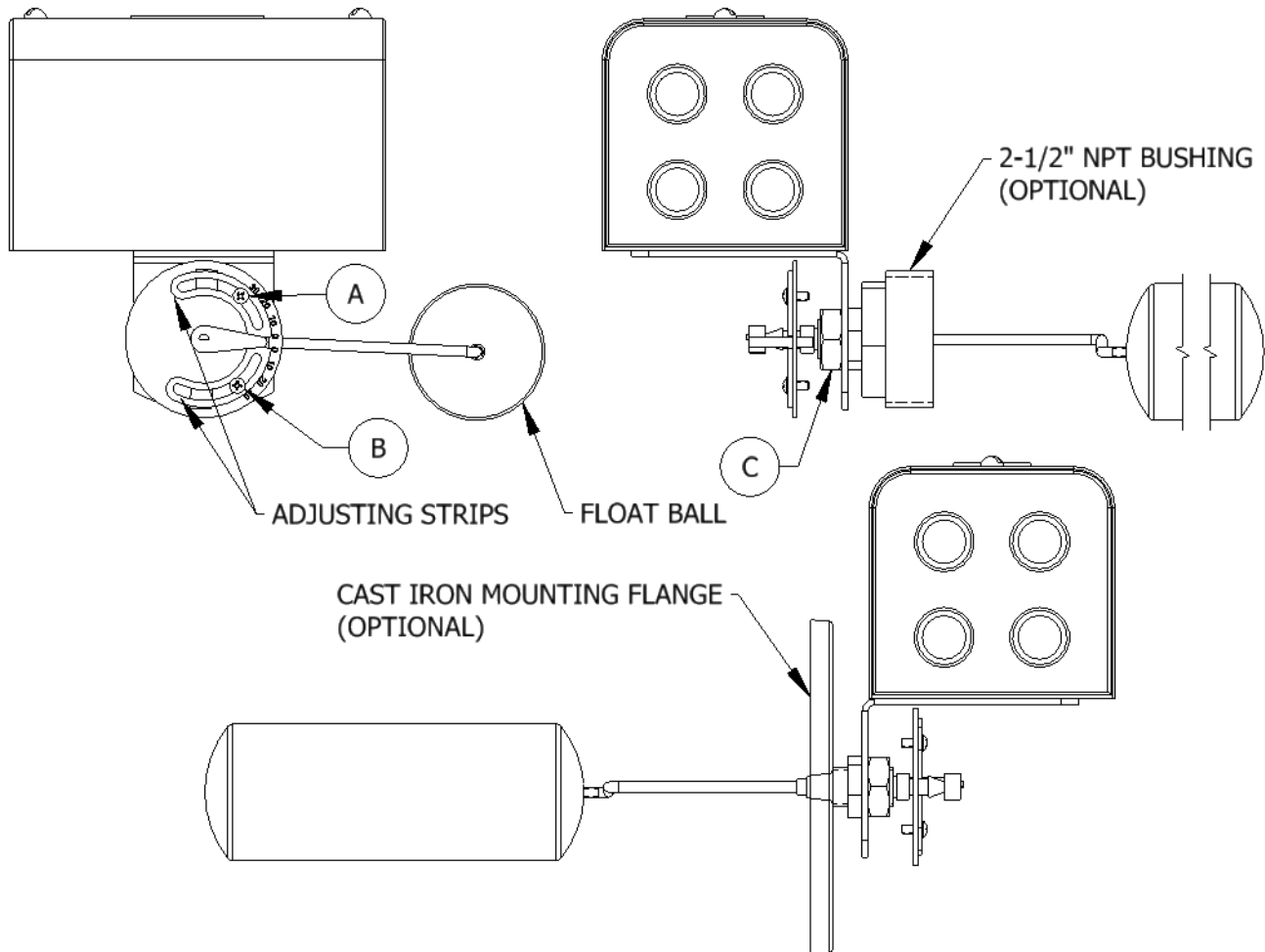

### **WARNING**

**TO AVOID SHOCK HAZARD, DISCONNECT ALL POWER BEFORE INSTALLING OR SERVICING DEVICE.**

**Float Adjustment:** Mechanical Alternators that are shipped with a Vent-Rite unit will be pre-set to the proper float travel; however, if a replacement float switch is to be installed on an existing unit or if adjustment is required, travel may be adjusted via the adjusting strips, held in place by bolts "A" and "B". Track secured by bolt "A" determines upward limit of travel, with "B" determining the lower. Either may be adjusted by loosening their respective bolts and sliding the adjustment track to the desired angle.

Note: If possible, filling the tank to desired high or low point will allow adjusting strip to be fastened in exact location, with no guesswork or calculation required.

Pump 1 will activate at roughly 3/4 of the vertical float travel, and alternate to pump 2 at the low end of the travel. If Pump 1 is not sufficient to empty the tank, pump 2 will activate at the high point of the float travel.

**Removing the Mechanical Alternator:** The side mount mechanical alternator can be mounted either with a 2-1/2" NPT bushing or a cast iron mounting flange. If a flange-mounted alternator must be removed from the tank, the nuts may be loosened on the flange and the float removed. Gaskets should be replaced if damaged. For the bushing mounted mechanical alternator, loosen the locking nut "C". This will allow the bushing to be rotated out of the tank and the alternator removed.

**Replacement Parts:** For replacement parts, contact your local Vent-Rite representative. Mechanical alternator arm and tank mounting configuration can differ from tank to tank, so be sure to provide the tank dimensions and mounting configuration in the request. Vent-Rite will not replace sub-components on the mechanical alternator, such as the float arm or switching mechanism.

**Wiring Diagrams:**

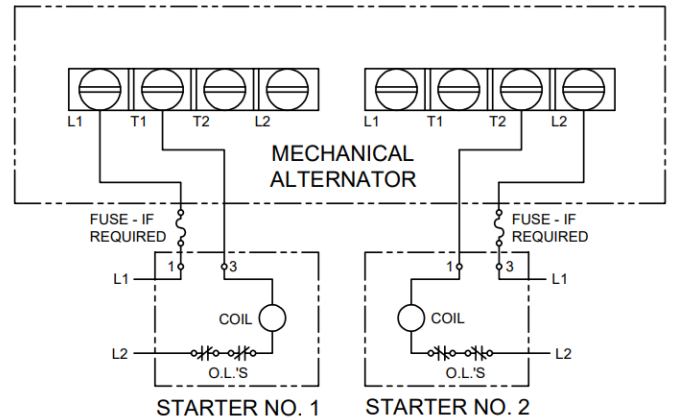
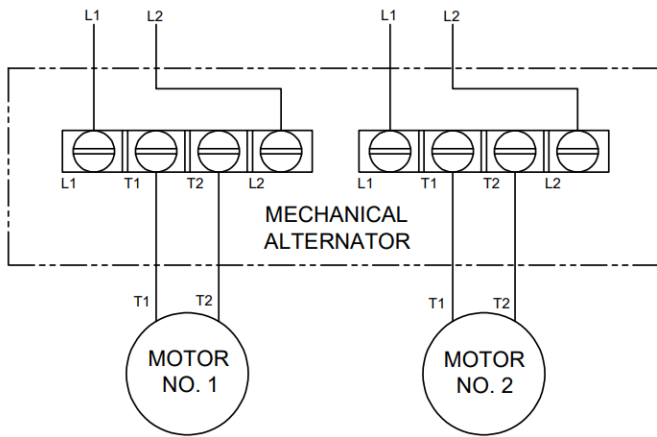

**Electrical Ratings:**

Voltage (V)	Single Phase AC	Three Phase AC	DC
<b>115</b>	2 HP	3 HP	1/2 HP
<b>208/230</b>	3 HP	5 HP	1/2 HP
<b>460/575</b>	-	1 HP	-
<b>32</b>	-	-	1/4 HP

Control Circuit Rating: A600

# TOP MOUNT FLOAT SWITCH - MAINTENANCE INSTRUCTIONS

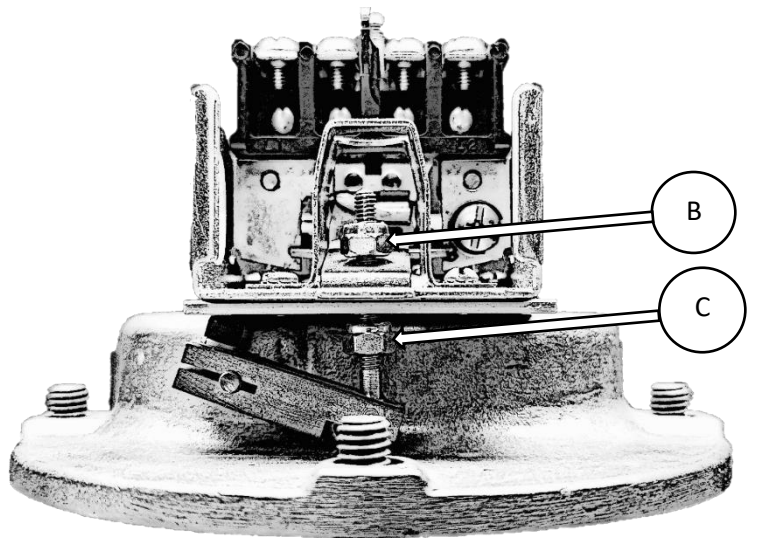
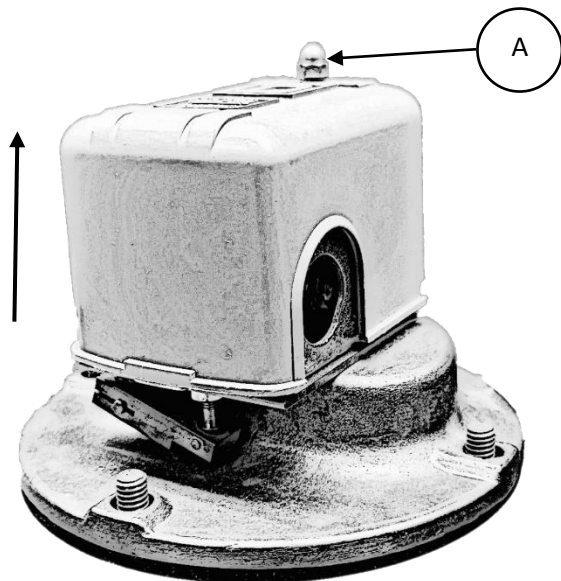
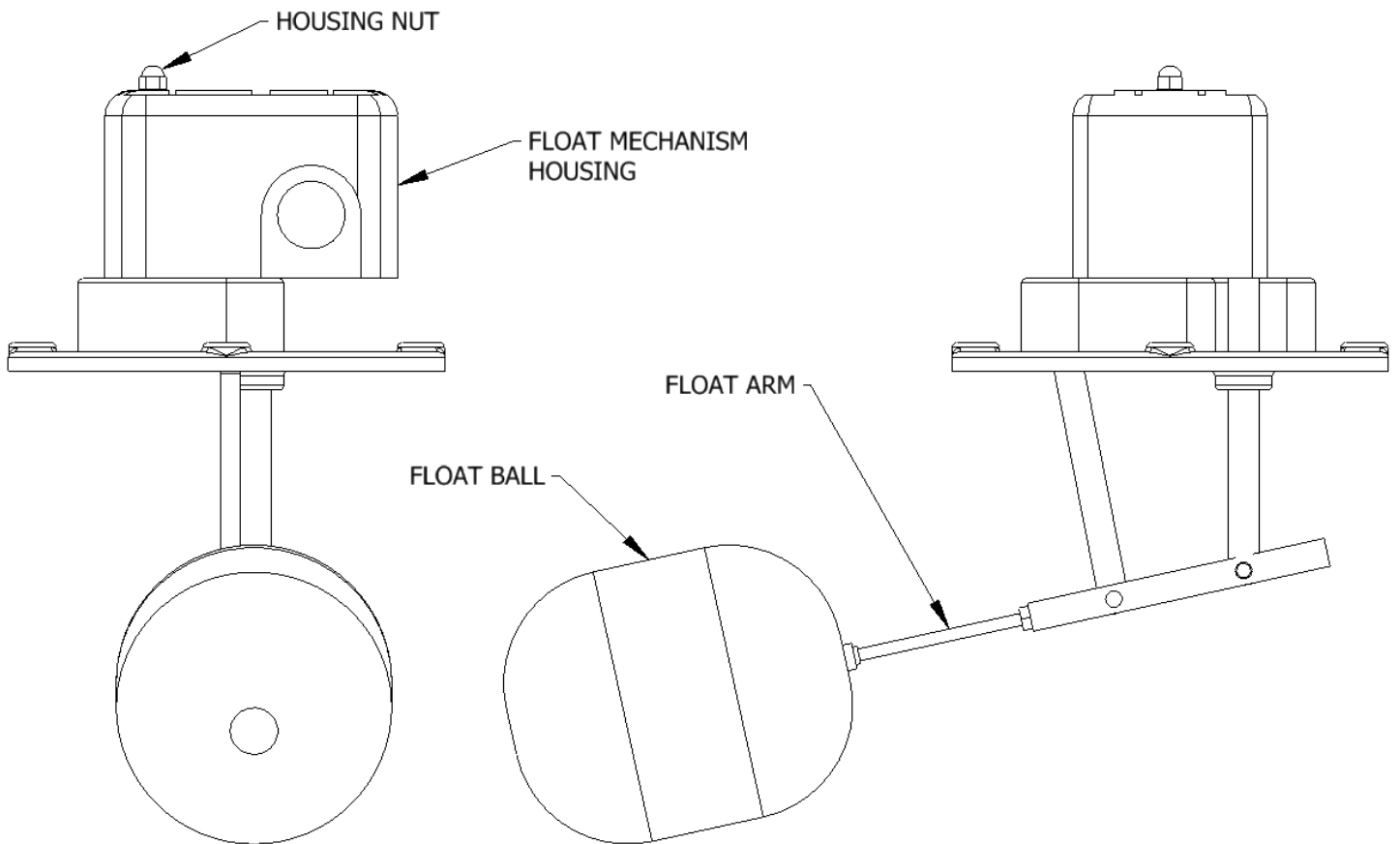

**⚠ WARNING**

TO AVOID SHOCK HAZARD, DISCONNECT ALL POWER BEFORE INSTALLING OR SERVICING DEVICE.

**Float Adjustment:** Floats that are shipped with a Vent-Rite unit will be pre-set to the proper float travel; however, if a replacement float switch is to be installed on an existing unit or if adjustment is required, travel may be adjusted via the adjusting nuts. These may be accessed by loosening housing nut “A” and sliding the housing off. By turning adjusting nut “B” and “C” closer together, float travel will be reduced, likewise turning the nuts further apart will increase float travel. **Do not tighten the bots together**, as this will bind the mechanism, always leave at least 1/16” of space between the bolts and the mechanism.

Note: If possible, filling the tank to desired high or low point will allow respective adjusting nut to be fastened in exact location, with no guesswork or calculation required.

**Removing the Float Switch:** The top mount float switch is mounted using an integrated flange. If the float must be removed from the tank, the nuts may be loosened on the flange and the float removed. Gaskets should be replaced if damaged.

**Replacement Parts:** For replacement parts, contact your local Vent-Rite representative. Float switch arm can differ from tank to tank, so be sure to provide the tank dimensions in the request. Vent-Rite will not replace sub-components on the float switch, such as the float arm or switching mechanism.

**Wiring Diagrams:**

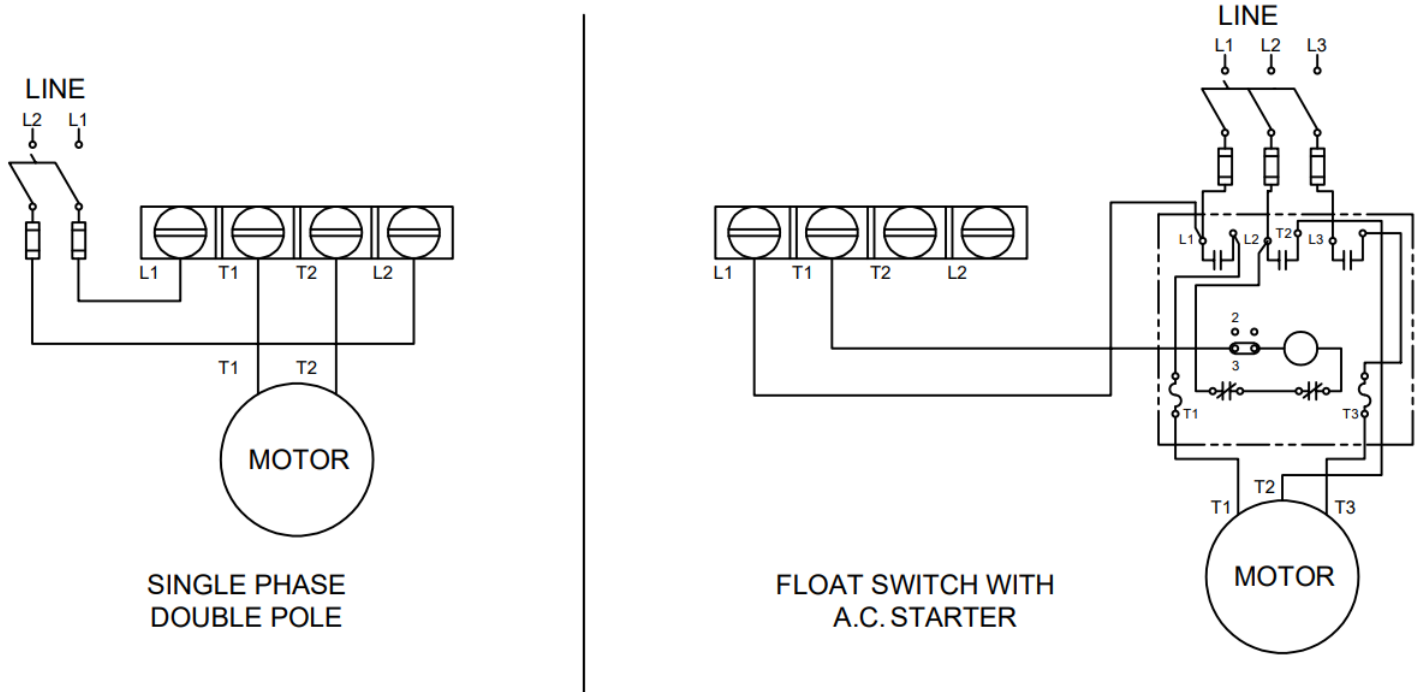

**Electrical Ratings:**

Voltage (V)	Single Phase AC	Three Phase AC	DC
115	2 HP	3 HP	1/2 HP
208/230	3 HP	5 HP	1/2 HP
460/575	-	1 HP	-
32	-	-	1/4 HP

Control Circuit Rating: A600

---

---

## TOP MOUNT MECHANICAL ALTERNATOR - MAINTENANCE INSTRUCTIONS

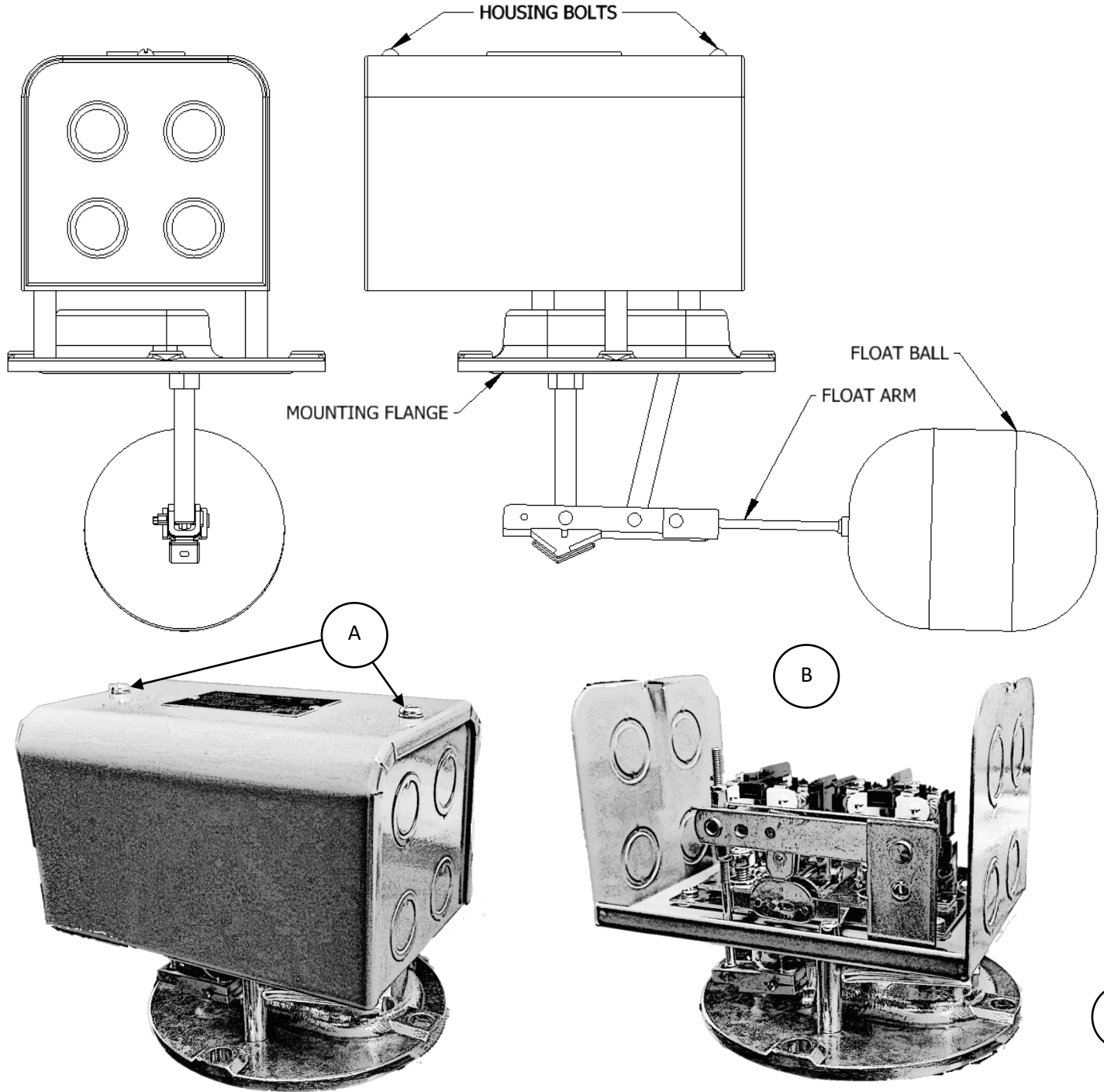

**⚠ WARNING**

**TO AVOID SHOCK HAZARD, DISCONNECT ALL POWER BEFORE INSTALLING OR SERVICING DEVICE.**

**Float Adjustment:** Floats that are shipped with a Vent-Rite unit will be pre-set to the proper float travel; however, if a replacement mechanical alternator is to be installed on an existing unit or if adjustment is required, travel may be adjusted via the adjusting nuts. These may be accessed by loosening housing nuts "A" and sliding the housing off. By turning

adjusting nut “B” and “C” closer together, float travel will be reduced, likewise turning the nuts further apart will increase float travel. “B” will adjust the high point, and “C” the low point. **These adjustments are very sensitive, so adjust only when absolutely necessary.**

Note: If possible, filling the tank to desired high or low point will allow respective adjusting nut to be fastened in exact location, with no guesswork or calculation required.

**Removing the Float Switch:** The top mount mechanical alternator is mounted using an integrated flange. If the alternator must be removed from the tank, the nuts may be loosened on the flange and the float removed. Gaskets should be replaced if damaged.

**Replacement Parts:** For replacement parts, contact your local Vent-Rite representative. Mechanical alternator arm can differ from tank to tank, so be sure to provide the tank dimensions in the request. Vent-Rite will not replace sub-components on the mechanical alternator, such as the float arm or switching mechanism.

**Wiring Diagrams:**

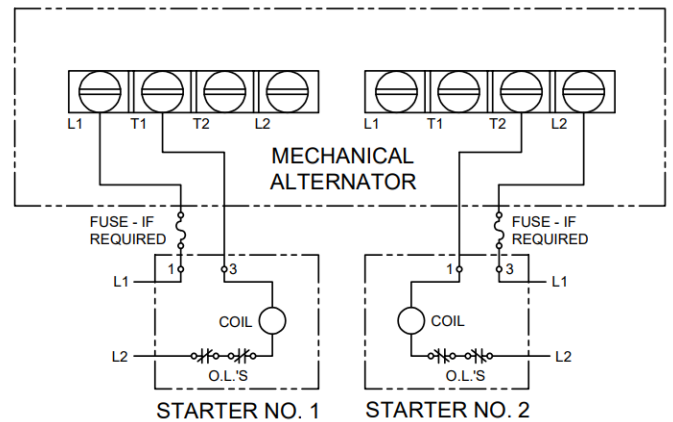
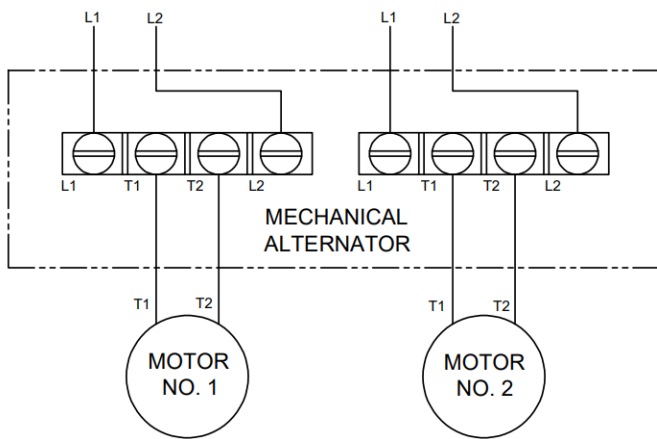

**Electrical Ratings:**

Voltage (V)	Single Phase AC	Three Phase AC	DC
115	2 HP	3 HP	1/2 HP
208/230	3 HP	5 HP	1/2 HP
460/575	-	1 HP	-
32	-	-	1/4 HP

Control Circuit Rating: A600

# Guardian Condensate Pump

## REPAIR PARTS LIST

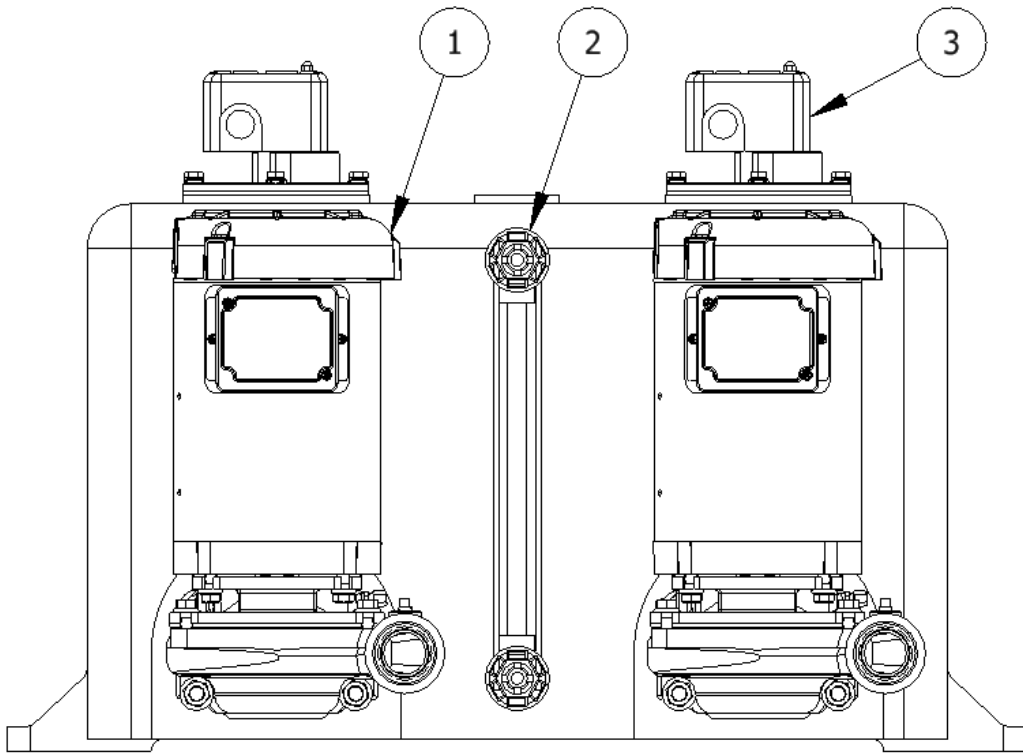

Figure 3

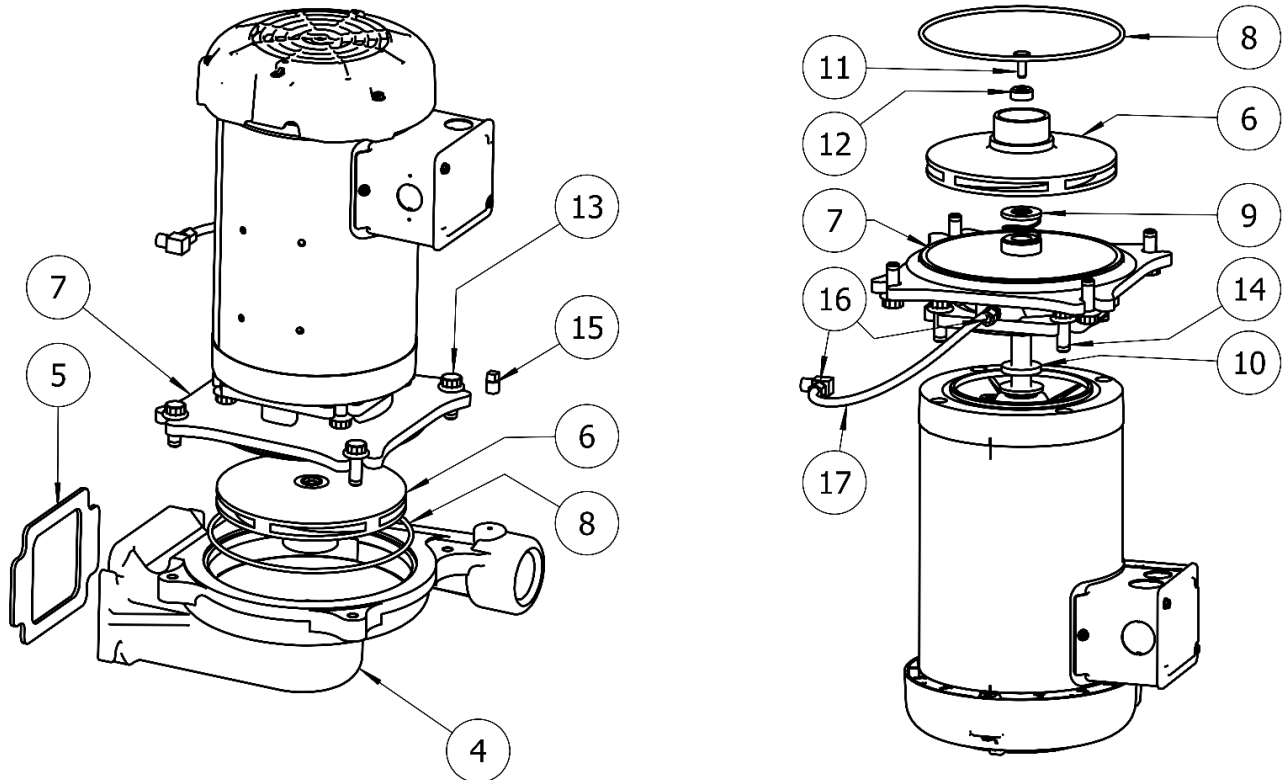

Figure 4 (G5V/G6V/G7V)

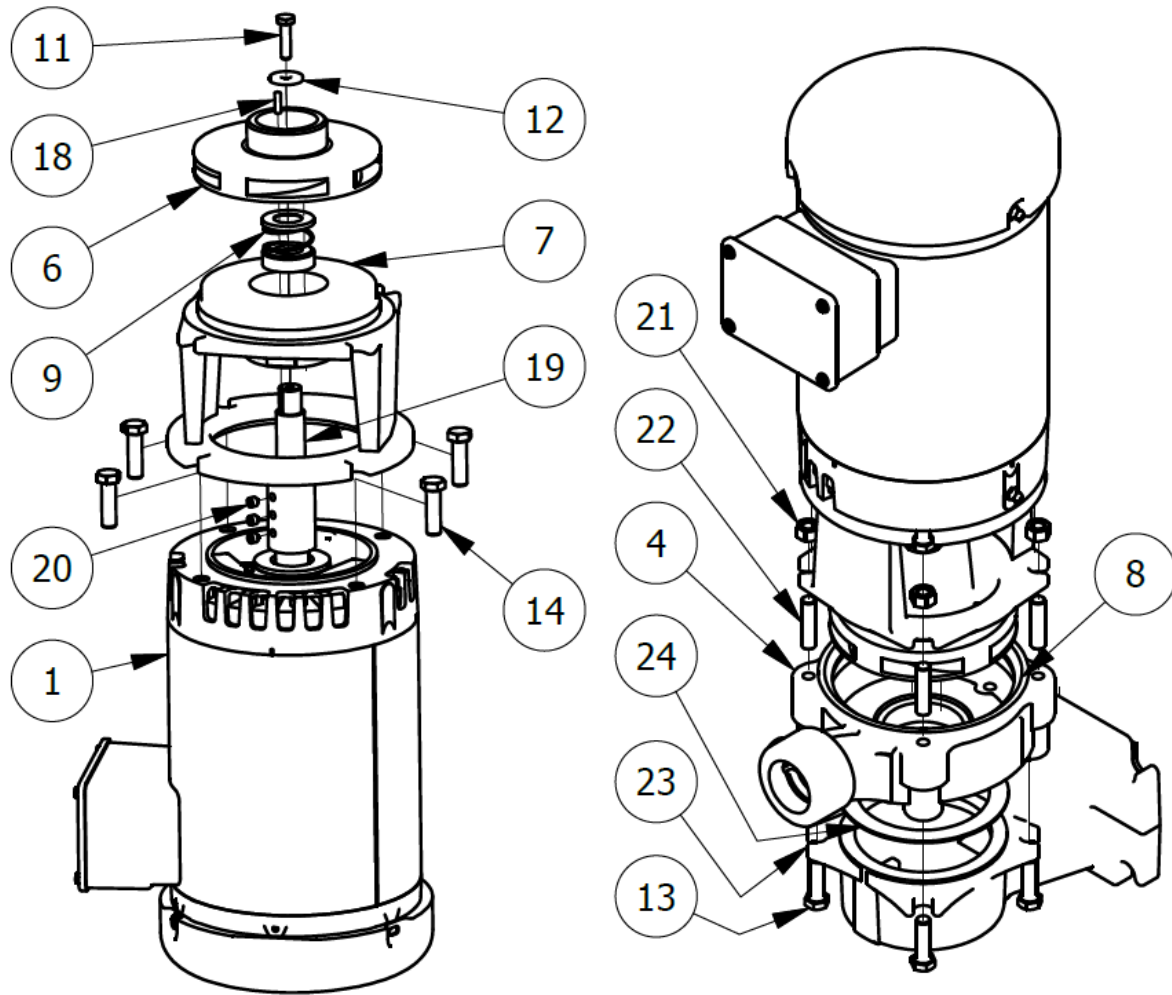

Figure 5 (GNV)

ITEM NUMBER	DESCRIPTION	SIMPLEX QUANTITY	DUPLEX QUANTITY
1	Motor	1	2
2	Gauge Glass	1	1
3	Float Switch	1	1
4	Volute	1	2
5	Tank Gasket	1	2
6	Impeller	1	2
7	Adapter Plate	1	2
8	Volute O-Ring	1	2
9	Mechanical Seal	1	2
10	Water Slinger	1	2
11	Impeller Bolt	1	2
12	Impeller Retainer	1	2
13	Volute Bolt	4	8
14	Motor Bolt	4	8
15	Volute Plug	1	2
16	Vent Fitting	1 Elbow, 1 Straight	2 Elbow, 2 Straight
17	Vent Line	1	2
18	Impeller Key	1	2
19	Extension Shaft	1	2
20	Set Screw	3	6
21	Nut	4	8
22	Stud	4	8
23	Volute Suction Adaptor	1	2
24	Volute Adaptor Gasket	1	2

**Table 2**

# Vent-Rite®

A Swan Group Company

1875 Dewey Avenue Benton Harbor, Michigan 49022  
 Phone 269.925.2522 Website: <http://ventritepump.com/>  
 MANUFACTURING AND DESIGN OF QUALITY HVAC SYSTEMS SINCE 1921

The specifications contained in this bulletin were effective at the time of publishing. We reserve the right to discontinue products at any time or to change specifications or design without incurring any obligation. For most current information, contact your Vent-Rite® representative.