

## VR, VRD, DV, DVD, & VARI-VAC® Model E3 Vacuum Pumps

### VACUUM PUMP SELECTION

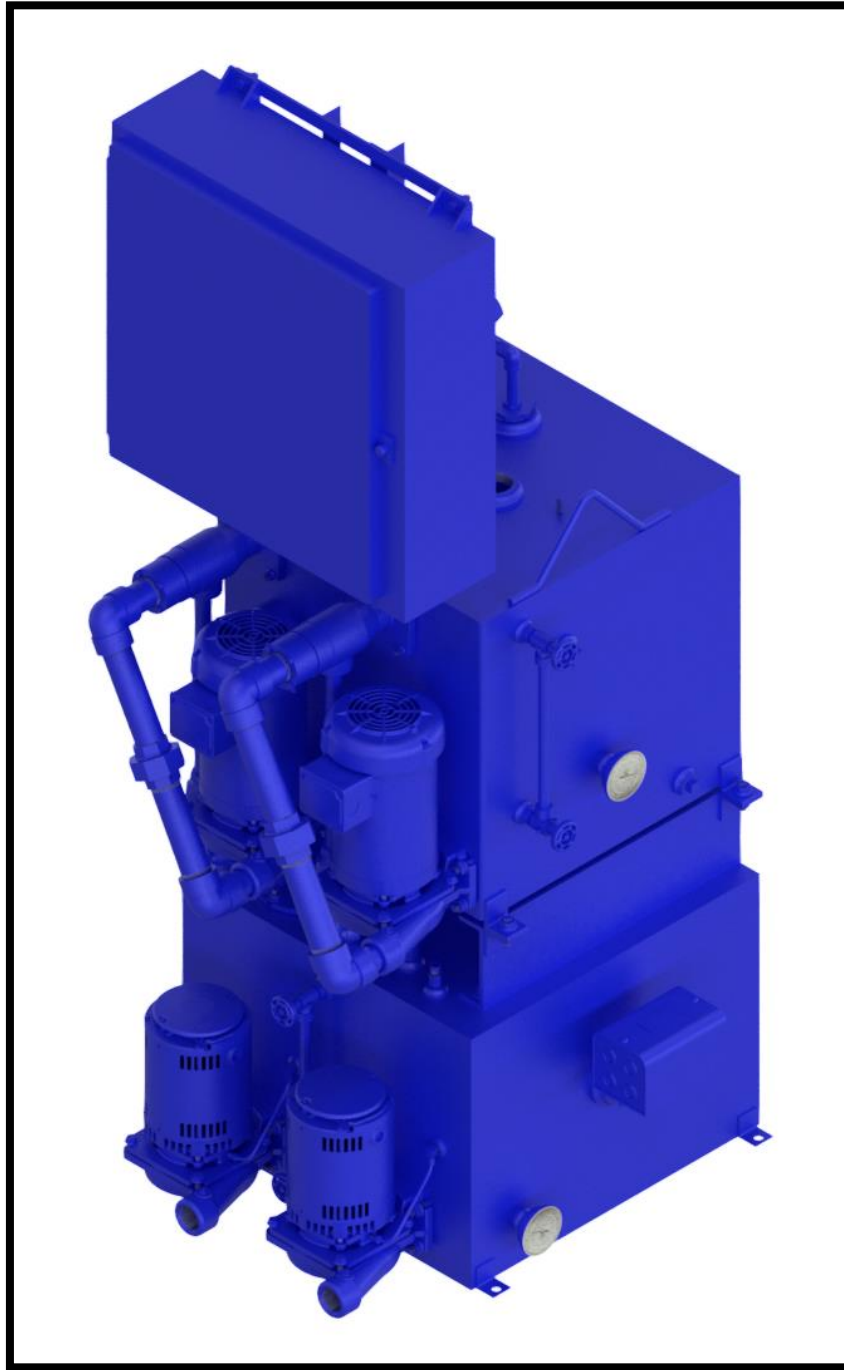

1875 Dewey Avenue  
Benton Harbor, MI 49022  
Phone 269-925-2522  
Website: <http://ventritepump.com/>

---

## APPLICATION

The Vacuum Pump is the heart of a steam heating system. For either new construction or retrofitting older systems, the rapid removal of air from the system speeds warm-up times while reducing fuel consumption. The Model E3 Vacuum Pump is manufactured in single, duplex or semi-duplex configurations in capacities ranging from 5,000 EDR through 65,000 EDR.

All Single Unit Pumps have a heavy-duty float switch, while Duplex Unit pumps are equipped with a mechanical alternator that not only gives stand-by service, but also alternates pump operation from one pump to the other on float control.

Both Single and Duplex Unit Pumps are equipped with vacuum switches and magnetic starters with selector switches. In addition, Single and Duplex Units have gauge glass, heavy copper-bearing steel receivers of large capacity and are so designed to take up minimum floor space.

---

## CONSTRUCTION FEATURES

**EXPERIENCE** - Vent-Rite® has manufactured vacuum pumps for over 100 years and this background in design and production expertise has gone into the Model E3. Each pump is tested prior to shipment in all aspects including its ability to pull 25 inches of vacuum. This deep vacuum capability with no increase in amp draw assures maximum energy savings on all jobs.

**EFFICIENCY** - With the use of the Model E3 Vacuum Pump, condensate is returned direct to the boiler or boiler feed pump, eliminating discharge valves and their associated costs. Less entrained air and other non-condensable gases

are returned to the boiler with the condensate. The use of high speed (3450 RPM) centrifugal pumps throughout the complete line insures greater motor and hydraulic efficiency.

**FLEXIBILITY** - Independence of condensate and hurling tanks offers great flexibility in design. CFM and GPM can be specifically suited to individual job requirements. High temperature limiting equipment is standard to meet even hostile operating conditions. Duplex units offer stand-by service and longer life in addition to having full rated capacity on each side.

---

## CONSTRUCTION DETAILS

**CENTRIFUGAL PUMP** - The Centrifugal Pumps employed are of design and manufacture and are of the close coupled type with mechanical seals suitable for temperatures to 250°F, 75 PSIG. The pumps are bronze fitted and suitable for working pressures to 150 PSI. A single Vacuum Pump has one Centrifugal Pump for pumping the condensate to the boiler or to a Boiler Feed Pump and one Centrifugal Pump for the air handling capability. There are two each in a full duplex.

**EXHAUSTER** - A jet-type exhauster of Vent-Rite design and manufacture offers reliable operation with its time-tested vacuum generation mechanism.

**TANKS** - The hurling tank or air separator tank is standard 3/16" copper bearing steel. The condensate receiver or accumulator tank is available in either 3/16" copper bearing steel or cast iron. The accumulator tank with low inlet has the Condensate Return Pump(s) mounted. It is also furnished with a thermometer. The hurling tank has the Air Handling Centrifugal Pump(s) and Exhauster(s) mounted. It is also furnished with a Gauge Glass.

**ELECTRICAL CONTROLS** - Furnished as standard are a float switch on a single pump or a mechanical alternator on a duplex pump that are mounted on the accumulator tank. A vacuum switch is furnished on the accumulator tank for a single or a duplex unit. One vacuum switch brings on both pumps on a duplex speeding up the recovery time on this important function. A control panel is furnished that includes magnetic starters for both the Water Pump and the Air Pump. Three position selector can be furnished as an option. Three position selector switches are furnished in the starters marked HAND-OFF AUTOMATIC. Three (3) position selector switch(es) for the centrifugal pump(s) on the top tank (hurling tank) function as follows:

In the HAND position, the pump operation is continuous. In the OFF position, the pump is off or if a separate accumulator tank is used, it will operate from the float switch on the separate accumulator tank. In the AUTOMATIC position, the vacuum switch controls the pump(s).

## CONSTRUCTION DETAILS (cont.)

The switch(es) for the pump(s) on the lower tank (accumulator tank) function as follows:

In the HAND position, it is continuous. In the OFF position, the pump(s) is (are) off. In the AUTOMATIC position, the pump(s) is (are) controlled from the float switch or mechanical alternator in the lower tank.

Wiring is factory completed to the motor(s). A reverse acting float and temperature limit switch are installed in the hurling tank and in conjunction with a solenoid valve to guard against low water level overheating.

**MOTORS** - Name brand motors 3450 RPM are used for the Centrifugal Pumps. They are 115-230/60/1 or 230-460/60/3 or 200-208/60/3. They are open drip proof motors with end covers to protect them as they are mounted in a vertical position. 3 HP and larger are available 3 phase only.

**ACCESSORIES** - All units are supplied with pressure gauges for the discharge of all Centrifugal Pumps and a vacuum gauge for the accumulator tank.

## CAPACITIES

PUMP SIZE		5	10	15	20	25	30	40	65
SQ. FT. RADIATION (EDR)		5,000	10,000	15,000	20,000	25,000	30,000	40,000	65,000
BOILER HORSEPOWER		36	71	107	143	178	214	286	464
BTU (MILLION)		1.20	2.40	3.60	4.80	6.00	7.20	9.60	15.60
SIMULTANEOUS CAPACITY	WATER GPM	7.5	15	22.5	30	37.5	45	60	97.5
	AIR CFM	2.6	6.1	7.1	8.2	12.4	14.4	22	36
MOTOR HP AIR		3/4	1	1	1 1/2	2	3	3	5
MOTOR HP WATER	10# DISCH.	1/3	1/3	1/3	1/2	1/2	1/2	-	-
	20# DISCH.	1/2	1/2	3/4	3/4	3/4	1	2	3
	30# DISCH.	3/4	3/4	1	1	1	1 1/2	3	3
	40# DISCH.	1	1	1	1 1/2	1 1/2	3	3	5

Water capacities are three (3) times maximum normal condensing rate. The air handling capability is substantially more than required for a reasonably tight system. Additional air capacity can only compensate for excessive leaks, and these should be corrected in the interest of energy conservation and reduced system component maintenance. On a duplex each side has full rated capacity.

## DIMENSIONAL MODEL

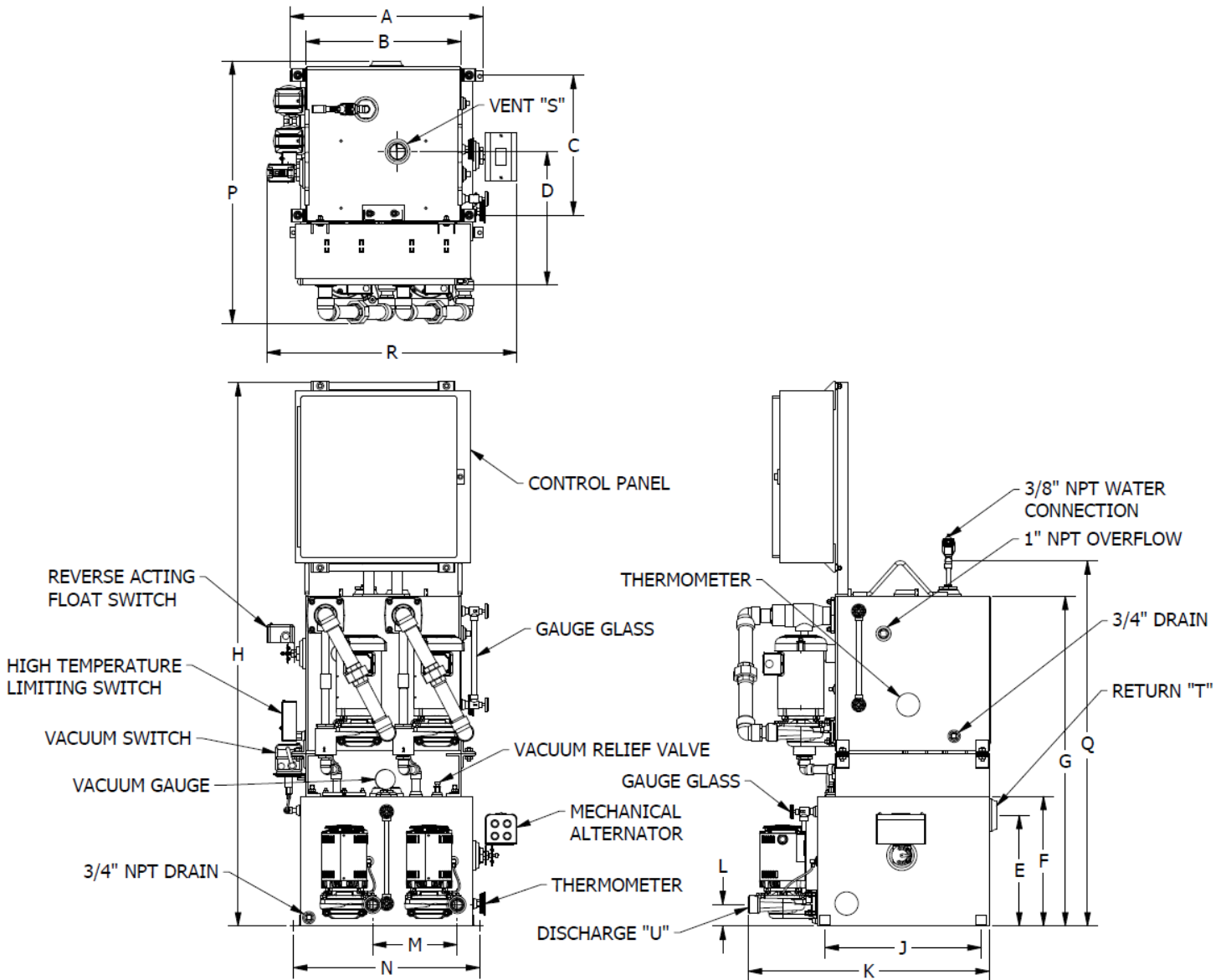

WATER PUMP EDR	DIMENSIONS IN INCHES										CAPACITY IN GAL.	
	A	B	C	D	E	F	G	H	J	K	ACCUM. TANK	HURLING TANK
5, 10, 15	31 3/4	22	19 13/16	18 1/8	14 1/2	17	46 3/4	77	20	35 3/4	45 (Cl.)	43
5, 10, 15	27 3/8	22	19 13/16	18 1/8	15 11/16	18 3/8	46 11/16	77	22 1/8	34 1/8	45 (ST.)	43
20, 25, 30	33 1/2	22	19 13/16	19 1/8	19	21 7/8	50 3/16	80 7/16	22 3/4	38 3/4	65 (Cl.)	43
20, 25, 30	27 3/8	22	19 13/16	19 1/8	21 11/16	24 3/8	52 11/16	82 15/16	22 1/8	34 1/8	65 (ST.)	43
40, 65	42	31	31	15 5/8	19 1/2	22 3/8	52 5/8	82 7/8	32	43 1/4	110 (Cl.)	96
40, 65	46	31	31	15 5/8	16 9/16	20 1/2	50 3/4	81	25	40 1/4	110 (ST.)	96

WATER PUMP EDR	DIMENSIONS IN INCHES										CAPACITY IN GAL.	
	L	M	N	P	Q	R	S	T	U	ACCUM. TANK	HURLING TANK	
5, 10, 15	3	15	28 3/4	40 1/4	51 3/4	36 7/16	2	2 1/2	1 1/4	45 (Cl.)	43	
5, 10, 15	3	12	26 3/8	37 3/16	51 11/16	34 1/2	2	2 1/2	1 1/4	45 (ST.)	43	
20, 25, 30	3 1/8	15	30 1/2	40 9/16	59 7/8	37 1/4	2	3	1 1/4	65 (Cl.)	43	
20, 25, 30	3	12	26 3/8	37 3/16	57 3/4	34 1/2	2	2 1/2	1 1/4	65 (ST.)	43	
40, 65	3 1/8	15	36 1/4	50 1/4	57 11/16	48 5/8	2 1/2	5	1 1/2	110 (Cl.)	96	
40, 65	3 1/8	22	45	48 1/2	55 13/16	51	2 1/2	4	1 1/2	110 (ST.)	96	

Note: 96 Gallon hurling tanks may be mounted on 45 & 65 Gallon accumulator tanks with a specially designed stand if higher vacuum is required. Please contact your Vent-Rite representative for submittal drawings.

## TYPICAL ENGINEERING SPECIFICATIONS

### 1. Model E3 Vacuum Pump

- 1.1. The contractor shall furnish and install as specified in the plans and in accordance with the manufacturer's instructions, one Vent-Rite® type Model E3 Vacuum Pump. Each pump, when exhausting against a closed orifice, shall produce a minimum of 20" of mercury vacuum with water 125° F.
- 1.2. The unit shall consist of two tanks, close coupled centrifugal pumps, and the necessary controls. The lower accumulator tank has a low inlet and is furnished with a float operated control device and a thermometer. The Upper hurling tank is furnished with a reverse acting float switch and electric solenoid with strainer for water loss through evaporation, a water level gauge, and high temperature limit switch. The unit is also furnished with pressure and vacuum gauges.
- 1.3. The vertically mounted close coupled centrifugal pump(s) for the condensate return shall be bronze fitted with an enclosed impeller, mechanical seal rated to 250° F, 75 PSIG and shall be driven by a motor operating at 3450 RPM.
- 1.4. The vertically mounted close coupled centrifugal pump(s) for the air separator unit shall be bronze fitted with an enclosed impeller, a mechanical seal rated to 250° F, 75 PSIG and shall be driven by a motor operating at 3450 RPM.
- 1.5. In addition to the above-mentioned electrical controls, the unit will be furnished with a vacuum switch and NEMA 1 Control panel. Control panel shall include 2 three-position selector switches marked HAND-OFF-AUTO and magnetic starters and fuse blocks.

### 2. Model E3 Differential (Vari-Vac®) Pump

- 2.1. Furnish and install as directed by plans and manufacturer's instructions, one Vent-Rite® DV (single) or DVD (duplex) Vari-Vac® Differential Pump. The pump, when exhausting against a closed orifice, shall produce a minimum of 25" of mercury at sea level (or its equivalent at higher elevation) with water at 125° F.
- 2.2. The unit shall consist of two tanks, close-coupled centrifugal pumps, and the necessary controls. The lower accumulator tank is furnished with a float operated control device (float switch for simplex and electric solenoid with strainer for water loss through evaporation, a water level gauge, and high temperature limit switch.) The unit is also furnished with pressure and vacuum gauges.
- 2.3. The vertically mounted close-coupled centrifugal pump(s) for the condensate return shall be bronze fitted with an enclosed impeller, mechanical seal rated to 250° F, 75 PSIG and shall be driven by a motor operating at 3450 RPM.
- 2.4. The vertically mounted close coupled centrifugal pump(s) for the air separator unit shall be bronze fitted with an enclosed impeller, a mechanical seal rated to 250° F, 75 PSIG and shall be driven by a motor operating at 3450 RPM.
- 2.5. In addition to the above mentioned electrical controls, the unit will be furnished with a vacuum switch and NEMA 1 Control panel. Each control panel shall include two three-position selector switches marked HAND-OFF-AUTO and two magnetic starters, two fuse block assemblies (one for air separator pump, one for condensate pump). Control circuit voltage to be 24 volts.
- 2.6. Furnish and install as directed by plans and manufacturer's instruction Differential Controllers which shall be connected at remote locations to both steam and return piping of the zones in which they are located. Lift fittings are not to be used in the heating system; the only lift permitted is between the separate accumulator tank when used and the pump. All return condensate must gravitate ahead of the Vari-Vac® Vacuum Pump, in a pit if necessary. Contractor shall complete piping and wiring connections to the vacuum pump.

Vent-Rite® Model No.	Water Pump Quantity (Simplex or Duplex)	Water Pump EDR (x1000)	Water Pump Discharge Pressure (psig)	Water Motor Power (HP)	Water Motor Speed (RPM)	Water Motor Voltage (V)	Water Motor Phase
	Water Motor Frequency (HZ)	Air Pump Quantity (Simplex or Duplex)	Air Motor Power (HP)	Air Pump Vacuum Generated (CFM at 5½" mmhg)	Accum. Tank Capacity (GAL)	Accum. Tank Material (Steel or C.I.)	Hurling Tank Capacity (GAL)

# Vent-Rite®

A Swan Group Company

1875 Dewey Avenue Benton Harbor, Michigan 49022  
 Phone 269.925.2522 Website: <http://ventritepump.com/>

**VARI-VAC®**

**MANUFACTURING AND DESIGN OF QUALITY HVAC SYSTEMS SINCE 1921**

The specifications contained in this bulletin were effective at the time of publishing. We reserve the right to discontinue products at any time or to change specifications or design without incurring any obligation. For most current information, contact your Vent-Rite® representative.