



Guardian Series

Vent-Rite[®]
A Swan Group Company

Guardian Series

Designed to protect your steam system, the Vent-Rite Guardian Series is reliable, cost-saving, and time-saving. It's easy to use, easy to maintain, and available for quick ship.

Overview

Cast iron and carbon steel receivers
Simplex and duplex units
Standard receiver capacities from 6 to 100 gallons

Guardian Features & Specifications

- Space-saving mechanical configurations
- Mechanical seals able to withstand temperatures up to 250°F
- Easy, low-maintenance service
- Simple in-field hookup
- Motors ranging from 1/3 hp to 5 hp available in 115, 208, or 230 single phase, 1,800 RPM

Guardian Condensate Return

Capacity
8,000 to 12,000 sq. ft. EDR or 10–20 gpm

Discharge Pressures
15–20 psi with 3,450 rpm units

Guardian condensate return pumps quickly collect and return condensate back to a boiler feed unit. The pump action is controlled by either a float switch (simplex) or a mechanical alternator (duplex) designed to energize the pump motor when liquid levels get too high. Various sizes of cast iron or carbon steel receivers are available to meet just about any installation requirement.

Cast Iron Receiver (Duplex Unit shown)

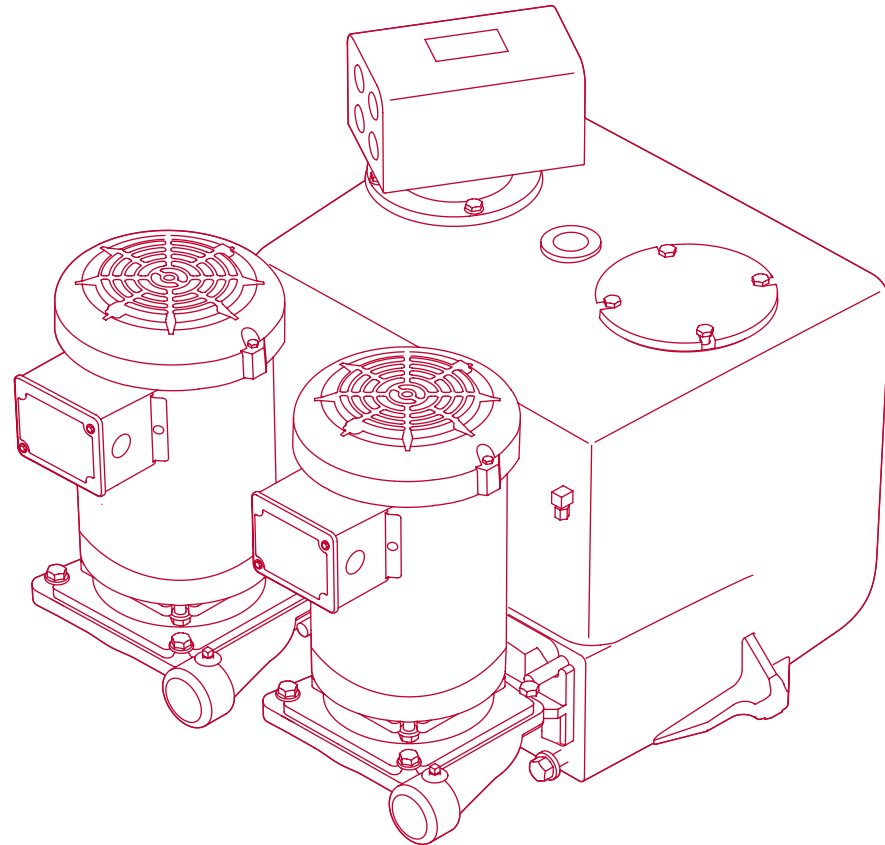

Guardian Boiler Feed

Capacity
8,000 to 12,000 sq. ft. EDR or 10–20 gpm

Discharge Pressures
15–20 psi with 3,500 rpm units

Guardian boiler feed pumps are used to pump condensate and makeup water directly into the boiler(s). Pump action is controlled by a boiler-mounted level controller that senses boiler water-level requirements. Each Guardian boiler feed pump includes a glass water level gauge with sight glass, and it is also equipped with a solenoid makeup valve and reverse-acting float switch to bring in makeup water. Various sizes of carbon steel receivers are available to meet just about any installation requirement.

Carbon Steel Receiver (Duplex Unit shown)

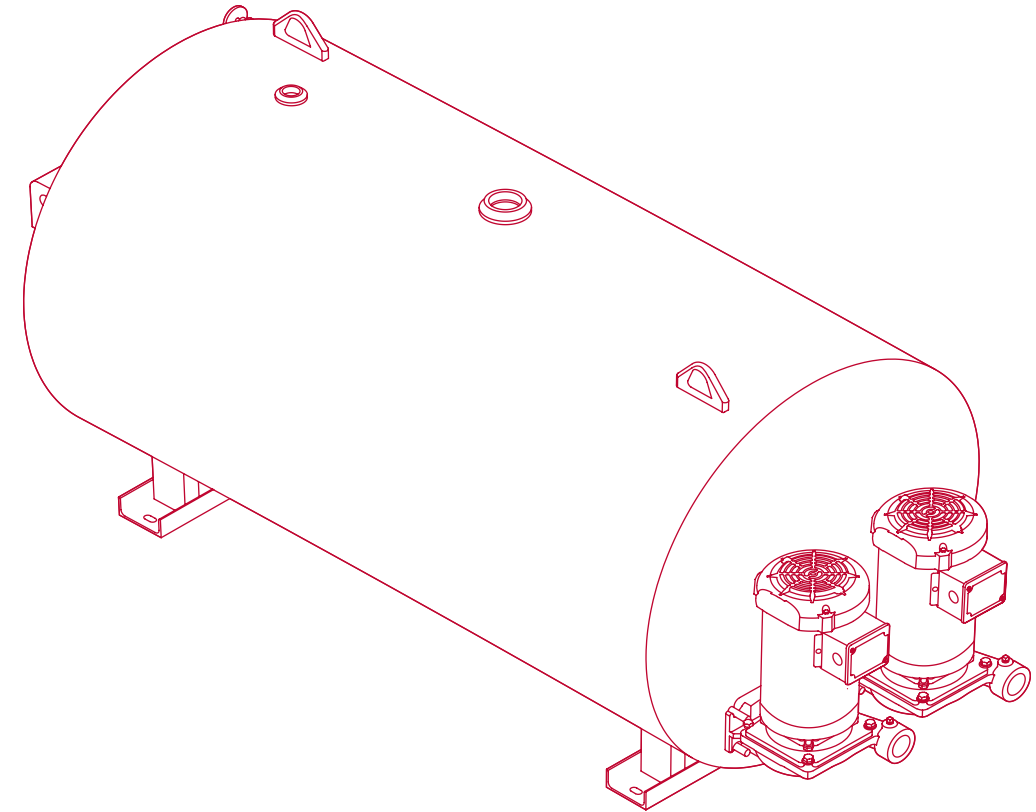



Acquired from Barnes & Jones Inc. in 1979, Vent-Rite Valve Corp. was established by its current parent company, The Swan Group, in 1984. Since 2004, VRVC has used MEPCO designs for Condensate and Boiler Feed Systems and MEPCO Vacuum Systems.

And through it all, we've always been focused on putting quality first. Not only do we believe in making great products for our customers, but we believe in doing it right—every single time. That's why every pump that leaves our doors has been carefully crafted and tested against the strictest standards, ensuring you receive the safest, highest-quality product possible.

ventritepump.com

1875 Dewey Avenue
Benton Harbor, MI 49022

(269) 925-8812