

Condensate Pump, type *Guardian* Unit Product Bulletin

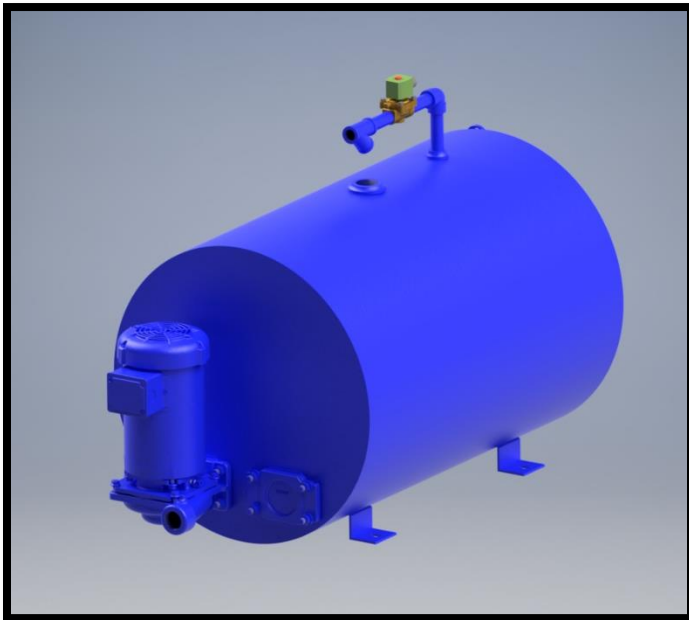

Guardian Condensate Return Unit

Guardian Boiler Feed Unit



1875 Dewey Avenue
Benton Harbor, MI 49022
Phone 269-925-2522
<http://ventritepump.com/>

INTRODUCTION

Easy to use and maintain, the Guardian pumps operate quickly and reliably. Available in simplex or duplex units, as well as condensate return or boiler feed units, all Guardian series units are capable of handling hot (210°F) or cold water. Many units have low profiles for low-headroom applications.

Guardian Condensate Return units are designed to collect and quickly return condensate to the boiler feed unit in low-pressure steam heat systems. Pumping action is controlled by the water level inside the receiver and a float device is used to turn the pump(s) on and off.

Each Guardian Boiler Feed pump includes a glass water level gauge with sight glass, and it is also equipped with a solenoid makeup valve and reverse-acting float switch to bring in makeup water. Pump action is controlled by a boiler-mounted level controller that senses boiler water-level requirements.

Guardian receivers are available in cast iron or carbon steel. Please note that steel receivers come in a broad range of size options, making them perfect for space-saving configurations.

PUMP CHARACTERISTICS

FLOW (GPM)	PRESSURE (PSI)	NPSHR (FEET)
10	20	2'
20	15	3'

TYPICAL CATALOGUE CODE

EXAMPLE: G S B D 49 A

GUARDIAN SERIES
 RECEIVER CONSTRUCTION
 (C = CAST IRON, S = STEEL)
 BOILER FEED
 DUPLEX
 RECEIVER GALLON SIZE

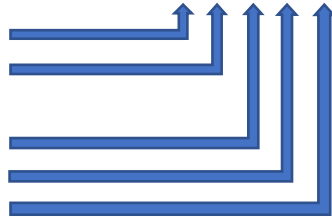

OPERATION

- Boiler Feed
- Condensate Transfer
- Air Conditioning
- Heating
- Liquid Transfer
- Residential Effluent
- Remote Liquid Transfer
- Assembly Line Drainage

FEATURES

- Multiple Profiles for Specific Applications
- Expertly Designed for Maneuverability
- Simplicity in Field Attachment
- Versatile Compatibility of Handling 210°F Water
- Competitively Priced
- Manufactured in the US by a Team of Professional Craftsmen
- Industry Leader in Prompt Delivery
- Large Selection to Fit Many Different Applications
- Simplex Units Equipped for Future Second Pump (Except for GC6A and GS10A)

PRODUCT DIMENSIONS

Note: All dimensions are approximate.

CAST IRON TANKS

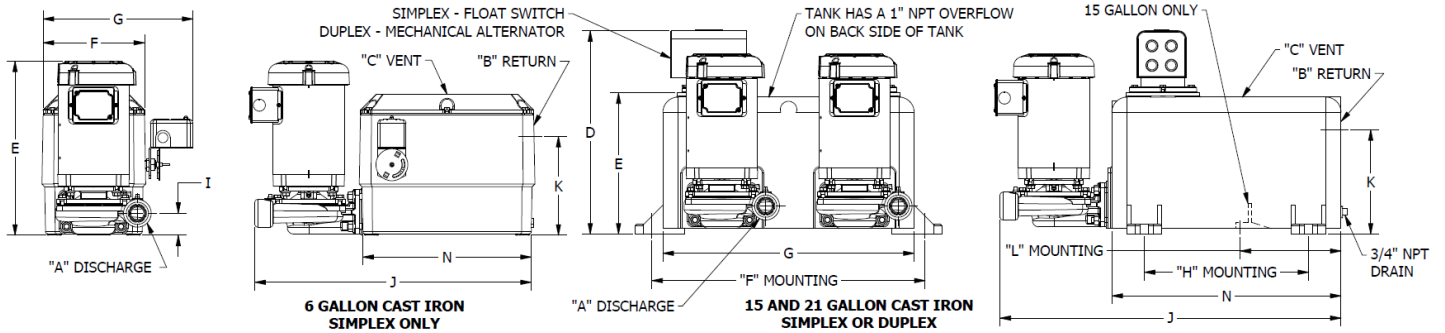

MODEL	UNIT STYLE	A	B	C	D	E	F	G	H	I	J	K	L	N	O
GC6A	Simplex 6 Gallon	1	2	1	-	12.8	9.2	14.2	-	2.2	25.1	9.1	-	15.7	-
GC15A	Simplex 15 Gallon	1	2	1	19.8	15.6	19.8	17.6	-	2.2	25.6	13.3	9.3	15.5	.6
GCD15A	Duplex 15 Gallon	1	2	1	22.1	15.6	19.8	17.6	-	2.2	25.6	13.3	9.3	15.5	.6
GC21A	Simplex 21 Gallon	1	2	1.2	17.5	12.7	25.5	22.7	14.9	3	31	10.2	-	20.7	.6
GCD21A	Duplex 21 Gallon	1	2	1.2	19.8	12.7	25.5	22.7	14.9	3	31	10.2	-	20.7	.6

RECTANGULAR STEEL TANKS

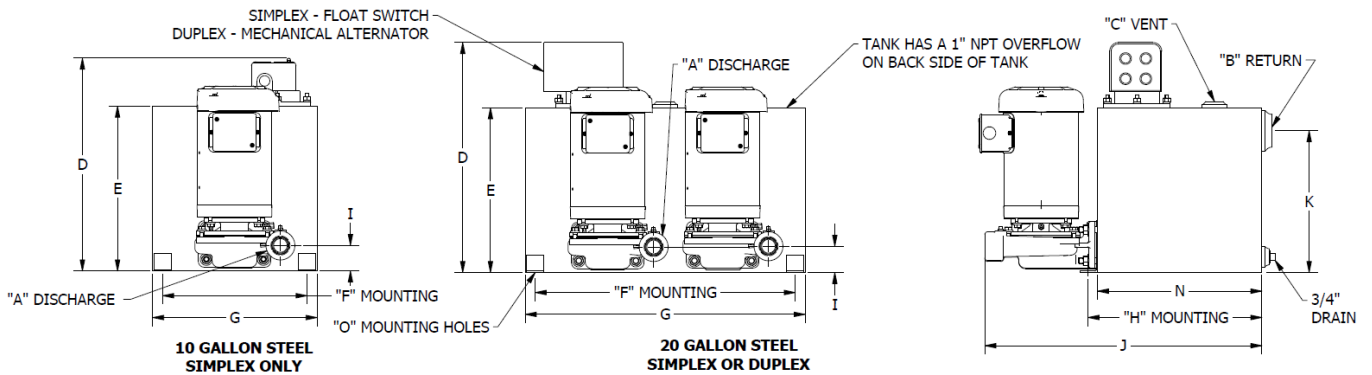

MODEL	UNIT STYLE	A	B	C	D	E	F	G	H	I	J	K	N	O
GS10A	Simplex 10 Gallon	1	2	1	18.5	14.2	12.5	14.3	15.2	2.2	24.1	12.2	14	.6
GS20A	Simplex 20 Gallon	1	2	1	18.5	14.2	22.5	24.3	15.2	2.2	24.1	12.2	14	.6
GSD20A	Duplex 20 Gallon	1	2	1	20.8	14.2	22.5	24.3	15.2	2.2	24.1	12.2	14	.6

CYLINDRICAL STEEL TANKS

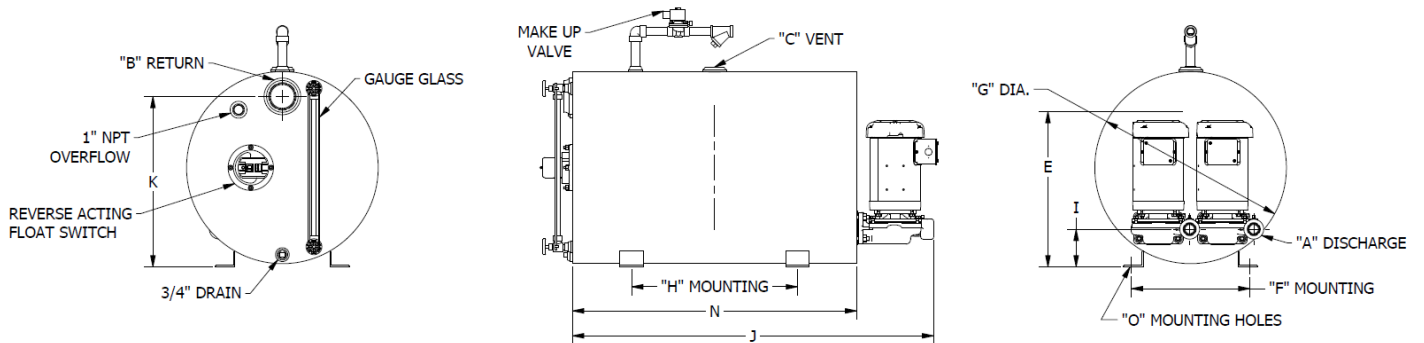

SIMPLEX	DUPLEX	UNIT STYLE	A	B	C	E	F	G	H	I	J	K	N	O
GSB49A	GSBD49N	49 Gallon	1	2.5	1.2	23	15	22	21	4.9	39.6	20.1	30	.6
GSB71A	GSBD71N	71 Gallon	1	3	1.5	25.4	15	24	21	4.7	45.6	21.5	36	.6
GSB117A	GSBD117N	117 Gallon	1	4	2	25.4	15	24	30	4.7	69.6	21.2	60	.6

Note: All dimensions are approximate.

TYPICAL SPECIFICATION

1. Simplex or Duplex Condensate Pump with Cast Iron or Steel Receiver

- 1.1 Furnish and install according to plans and manufacturer's instructions the quantity of condensate pump units as shown on the drawings. Each unit shall consist of one (1) condensate receiver, (1-2) condensate pumps, and (1) float switch for simplex units, or (1) mechanical alternator for duplex units.
- 1.2 The condensate pumps shall be centrifugal design; permanently aligned and driven by vertical close coupled drip proof motors with drip covers. The motor and rotating parts shall be removable without disturbing suction or discharge piping. Pumps shall be bronze fitted with enclosed bronze centrifugal impeller, stainless steel shaft, dripless mechanical seals suitable for 250°F, mechanical seal face flushing line with vent to receiver. Capacities and electrical characteristics shall be as scheduled on the drawings.
- 1.3 The receiver shall be manufactured of rust resisting steel or cast iron and shall have a capacity of not less than that shown on the drawings.
- 1.4 (Optional) Pumps shall be furnished with a cast iron suction isolation with brass internal valve and sealed with a rubber O-ring.

Vent-Rite® Model No.	Pump Capacity (GPM)	Pump Discharge Pressure (psig)	Motor Power (HP)	Motor Speed (RPM)	Motor Voltage (V)	Motor Phase	Motor Frequency (HZ)	Tank Capacity	Tank Material
			1/3	3450 RPM	115/208-230	Single	60		

2. Simplex or Duplex Boiler Feed with Cast Iron or Steel Receiver

- 2.1 Furnish and install according to plans and manufacturer's instructions the quantity of boiler feed units as shown on the drawings. Each unit shall consist of one (1) steel boiler feed receiver, one or two (1-2) boiler feed pumps, one (1) float operated solenoid valve make-up assembly with "Y"-type strainer.
- 2.2 The boiler feed pumps shall be centrifugal design, permanently aligned and driven by vertical close coupled drip proof motor with drip cover. The motor and rotating parts shall be removable without disturbing suction or discharge piping. Pump shall be bronze fitted with enclosed bronze centrifugal impeller, stainless steel shaft, dripless mechanical seals suitable for 250°F, mechanical seal face flushing line with vent to receiver. Capacities and electrical characteristics shall be as scheduled on the drawings.
- 2.3 The receiver shall be manufactured of rust resistant steel and shall have a capacity of not less than that shown on drawings. Receiver shall be equipped with water level gauge glass and Vent-Rite® makeup water valve with capacity equal to one (1) boiler feed pump.
- 2.4 (Optional) Pumps shall be furnished with a cast iron suction isolation with brass internal valve and sealed with a rubber O-ring.

Vent-Rite® Model No.	Pump Capacity (GPM)	Pump Discharge Pressure (psig)	Motor Power (HP)	Motor Speed (RPM)	Motor Voltage (V)	Motor Phase	Motor Frequency (HZ)	Tank Capacity	Tank Material
			1/3	3450 RPM	115/208-230	Single	60		

Makeup Water Supply Pressure (psig)	Number of Boilers Serving	Number Standby



1875 Dewey Avenue Benton Harbor, Michigan 49022
 Phone: 269.925.2522 Website: <http://ventritepump.com/>
MANUFACTURING AND DESIGN OF QUALITY HVAC SYSTEMS SINCE 1921

The specifications contained in this bulletin were effective at the time of publishing. We reserve the right to discontinue products at any time or to change specifications or design without incurring any obligation. For most current information, contact your Vent-Rite® representative.